

VDI SAFETY

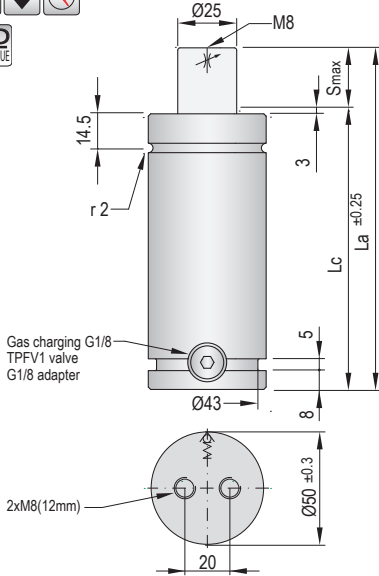

**i** Pressure medium **Nitrogen (N<sub>2</sub>)**

|                               |                      |
|-------------------------------|----------------------|
| Max. charging pressure        | 150 Bar              |
| Min. charging pressure        | 35 Bar               |
| Rod seal area                 | 4,91 cm <sup>2</sup> |
| Operating temperature         | 0°C - 80°C           |
| Force increase by temperature | 0,33 %/°C            |
| Max. stem speed               | 12 m/min             |
| Maintenance kit               | Kit SR750            |
| Recommended max. strokes/min  | 5 - 20 spm           |

ISO  
STANDARD  
DIMENSIONS



### Required data

|                            |         |
|----------------------------|---------|
| Working stroke             | (mm)    |
| Press speed                | (m/min) |
| Maximum production rate    | (spm)   |
| Gas spring expansion speed | (m/min) |



| Code         | Smax mm | La mm | Lc mm |                   | Fa daN            |       | F daN |  | Fc daN |  | P Bar         |  | V l   |  | Kg   |
|--------------|---------|-------|-------|-------------------|-------------------|-------|-------|--|--------|--|---------------|--|-------|--|------|
| TPSR 750x13  | 12,7    | 120,4 | 107,7 | 740 ±5%<br>(20°C) | 740 ±5%<br>(20°C) |       | 880   |  | 900    |  | 150<br>(20°C) |  | 0,035 |  | 1,20 |
| TPSR 750x25  | 25      | 145   | 120   |                   |                   |       | 955   |  | 990    |  |               |  | 0,048 |  | 1,35 |
| TPSR 750x38  | 38      | 171   | 133   |                   |                   |       | 995   |  | 1035   |  |               |  | 0,065 |  | 1,40 |
| TPSR 750x50  | 50      | 195   | 145   |                   |                   |       | 1020  |  | 1065   |  |               |  | 0,080 |  | 1,52 |
| TPSR 750x63  | 63      | 222   | 159   |                   |                   |       | 1035  |  | 1085   |  |               |  | 0,096 |  | 1,70 |
| TPSR 750x80  | 80      | 255   | 175   |                   |                   |       | 1055  |  | 1105   |  |               |  | 0,118 |  | 1,82 |
| TPSR 750x100 | 100     | 295   | 195   |                   |                   |       | 1065  |  | 1125   |  |               |  | 0,143 |  | 1,85 |
| TPSR 750x125 | 125     | 345   | 220   | 1080              | 1135              | 0,174 | 2,20  |  |        |  |               |  |       |  |      |

(Other strokes under order)

TPSR

TPSRs

TPNS

TPHT



### Force/stroke ratio

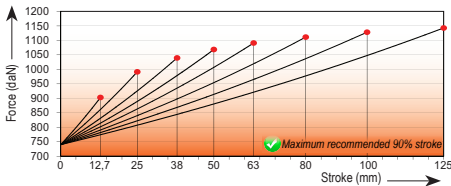

### Initial force/charging pressure ratio

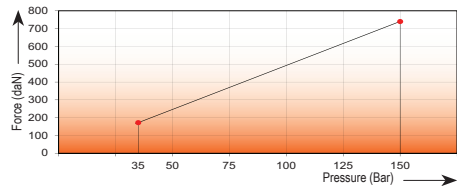

### Assembly possibilities

